

ENGINE SPECS:

- Layout- 3.0L 90 degree V8, flat plane crankshaft
- Bore & Stroke- 84mm x 68mm
- Compression ratio- 13:1
- Power- 450hp at 10,000 rpm (10,500 redline)
- Torque- 250 ftlbs at 8,000 rpm
- Valving- 4 camshaft, 4 valves per cylinder
- Clutch- 5.5" dual disc
- Special features-
 - Unique offset cylinders design reduces length of engine
 - Low profile with sump 95mm from crank centerline
 - One piece billet 7075 case with integral cylinders
 - Air/oil separator with manifold mounted multistaged oil pump

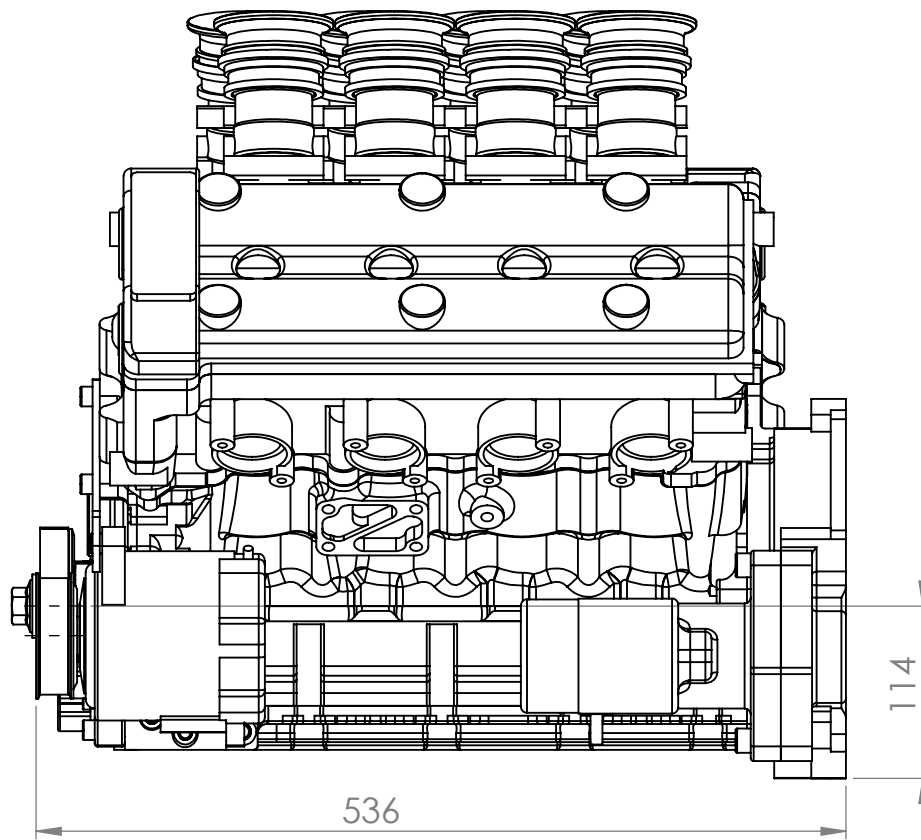
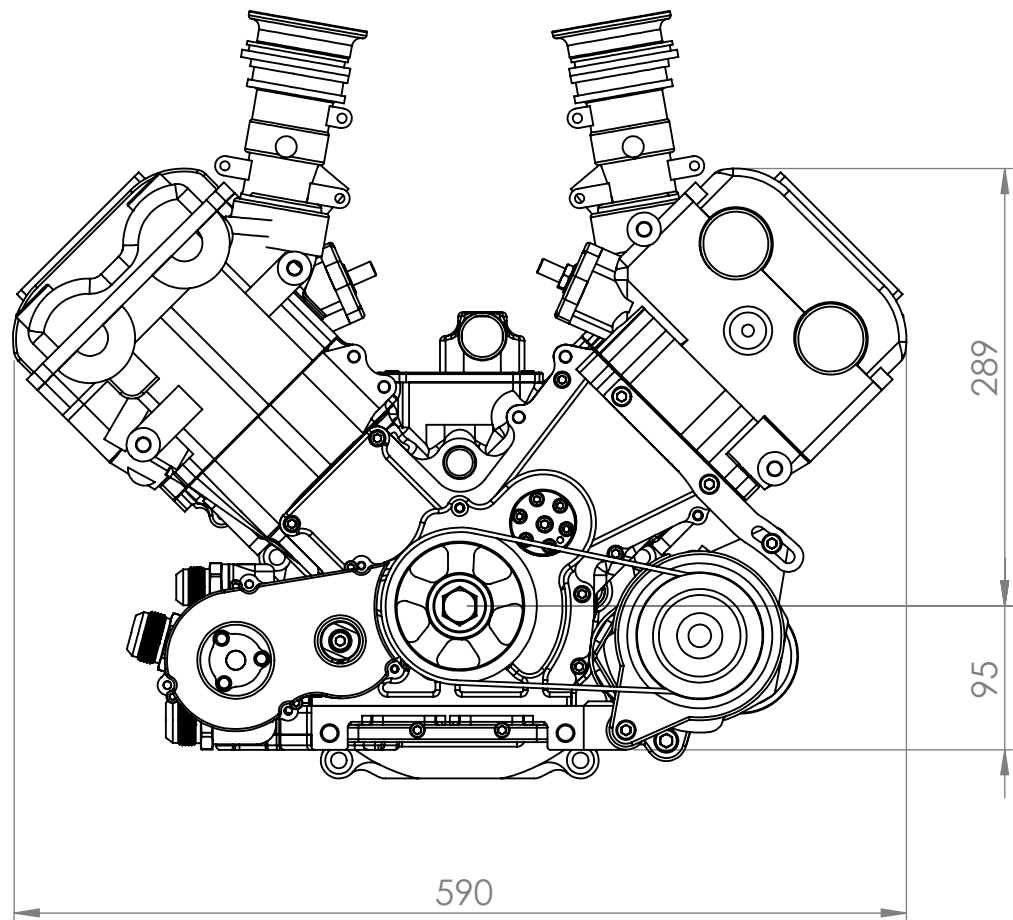
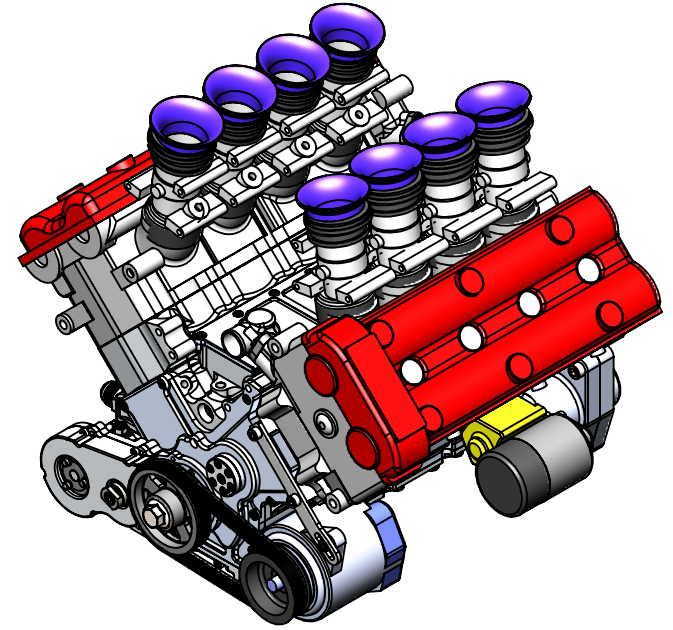

**GENERAL APPLICATION DRAWING
DO NOT USE FOR CONSTRUCTION**

PROPRIETARY AND CONFIDENTIAL
THE INFORMATION CONTAINED IN THIS DRAWING IS THE SOLE PROPERTY OF HARTLEY ENTERPRISES. ANY REPRODUCTION IN PART OR AS A WHOLE WITHOUT THE WRITTEN PERMISSION IS PROHIBITED.

		UNLESS OTHERWISE SPECIFIED:		NAME	DATE
		DIMENSIONS ARE IN INCHES		DRAWN	
		TOLERANCES:		CHECKED	
		FRACTIONAL ±		ENG APPR.	
		ANGULAR: MACH ± BEND ±		MFG APPR.	
		TWO PLACE DECIMAL ±		Q.A.	
		THREE PLACE DECIMAL ±		COMMENTS:	
		INTERPRET GEOMETRIC TOLERANCING PER:			
		MATERIAL			
		FINISH			
NEXT ASSY	USED ON				
APPLICATION		DO NOT SCALE DRAWING			
				TITLE:	
				3.0 L BOLT V8	
SIZE	DWG. NO.			REV	
B					
SCALE: 1:5		WEIGHT:		SHEET 1 OF 1	